



Hevi-Bar MD™
Mill Duty
Conductor Bar System





100% System Availability for Mission-Critical Mill Equipment

High Conductivity, Low Maintenance, Long Life Hevi-Bar MD™



Hevi-Bar MD™ Mill Duty Conductor Bar for Heavy Duty Mill Applications

Process cranes and other material handling electrification systems are subjected to demanding duty cycles, day in and day out, in challenging mill environments. Our mission is to help you keep this critical equipment up and running and to avoid costly downtime.

Whether you are electrifying hot metal ladle cranes or charging cranes, billet cranes, coil handling equipment, slab or scrap handling systems, **Hevi-Bar MD™** is the best choice.

Conductix-Wampfler's rugged **Hevi-Bar MD™** conductor bar system gives you peace of mind. The system will last for decades. It is literally the "put it up once and forget about it" solution.

Hevi-Bar MD™ combines the wearability and corrosion resistance of stainless steel with the electrical efficiency of aluminum for maximum conductivity. Stainless steel capped aluminum alloy bar is superior to copper bar, all-aluminum bar, or all-steel bar for carrying high currents with maximum service life.

Conductix-Wampfler's core competence is in the consulting, development, production, and commissioning of tailor-made, engineered conductor bar solutions that provide energy for critical moving machinery.

Our wide range of mobile electrification solutions can be adapted to your unique requirements. If you need reliable systems, optimum efficiency, and an experienced partner, look no further than Conductix-Wampfler. We are committed to your success.

The Welded Cap version of Hevi-Bar MD™ carries **US Patent # 6,983,834 B1**



Hevi-Bar MD™

High Conductivity, Long Life

Why Stainless Steel Capped Aluminum Conductor Bar?

Since the 1970s, energy efficient stainless steel capped aluminum alloy conductor bar systems have provided safe and reliable power in a variety of demanding operating conditions, in industry as well as mass transit systems.

Lower Electrical Resistance = Greater Electrical Efficiency

Aluminum alloy conductors have lower I^2R losses, which yields greater conductivity, less energy lost, and more power available for your cranes. You will never need parallel cables - as shown on page 5 at the bottom. The bar can accommodate the needed current demands.

The tight electrical bond between the stainless steel cap and aluminum alloy bar yields very low contact resistance.

Rust-free Contact Surface = Longer Bar Life

The stainless steel cap prevents the formation of non-conductive iron oxide at the collector shoe contact surface. This results in less erosion of the conductor from micro-arcing and less mechanical wear.

Easier to Handle = Lower Life Cycle Costs

Aside from substantial energy efficiency, AL/SS bar is lighter and easier to install than steel bars. All this adds up to lower total life-cycle costs versus all-steel or copper bars.

Longer Collector Shoe Life = Lower Maintenance Costs

Collector shoes glide easily on the low-friction stainless steel surface resulting in longer collector shoe life than with steel or copper bar.

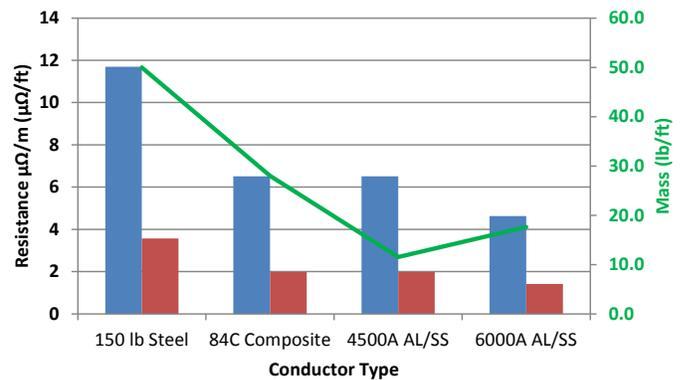

An example of excessive wear due to electrical erosion at the steel conductor bar joints.

Minimal surface wear of AL/SS bar allows you to reconfigure or add AL/SS bar sections decades later without ever having to grind the bar surfaces to match.

Hevi-Bar MD™'s stainless steel running surface stays clean and electrically conductive.



Capacity Options for Your High-Current Heavy Duty Electrification Needs

Two types of stainless steel caps are offered - Crimped or Welded - as shown on the right.

The stainless steel "Crimped Caps" on 2200, 3800, and 4500 bars are securely affixed to the aluminum alloy body. This version is ideal for applications using our collector assembly 56640 (see page 13).

The stainless steel "Welded Caps" on 3800, 4500, and 6000 bars are welded on the sides to provide a smooth, consistent running surface and maximum collector shoe life. This version is ideal for paddle-style collectors.

All conductor bar bodies are high-strength, corrosion-resistant aluminum alloy. When the aluminum alloy body expands thermally, the stainless steel cap actually tightens further, making it impervious to separation.

The smooth, durable contact surface of either the crimped or welded cap will withstand millions of collector shoe passes. Stainless steel hardware is used throughout the system.

The standard system is set up for 600 volts AC or DC, but can be configured for higher voltages.

No parallel cabling required with Hevi-Bar MD™ Conductor Bar.

The all-steel power bar at the right requires auxiliary cabling to carry the current.

2200 Amp Crimped Cap



3800 Amp Crimped Cap

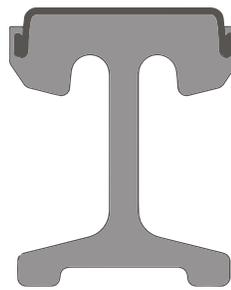

3800 Amp Welded Cap



4500 Amp Crimped Cap



4500 Amp Welded Cap



6000 Amp Welded Cap



Hevi-Bar MD™

Crimped or Welded Cap

Conductix-Wampfler: We Know Process Cranes. We Know Mills. We Can Supply the Right Solution for Your Needs

Two optional running surface configurations to provide the best value for your application.

2mm Stainless Steel Crimped Cap – firmly locked onto the aluminum alloy conductor bar

The standard design provides high reliability at an economical price.

- Excellent wear resistance – over 100 million shoe passes
- Durability and reliability
- Best when used with our self-centering pantograph collector



Crimped Cap Design (2200 Amps)

4mm Stainless Steel Welded Cap – welded around the sides of the conductor to provide wrap-around protection

- The heavy-duty design provides highest durability
- Outstanding wear resistance – over 200 million shoe passes
- Durability for the most severe environments
- May be used with all collector types, including cast-iron paddle designs

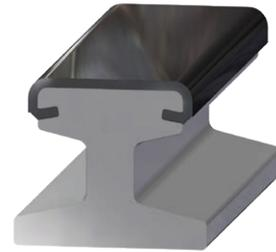

Welded Cap Design (6000 amps)

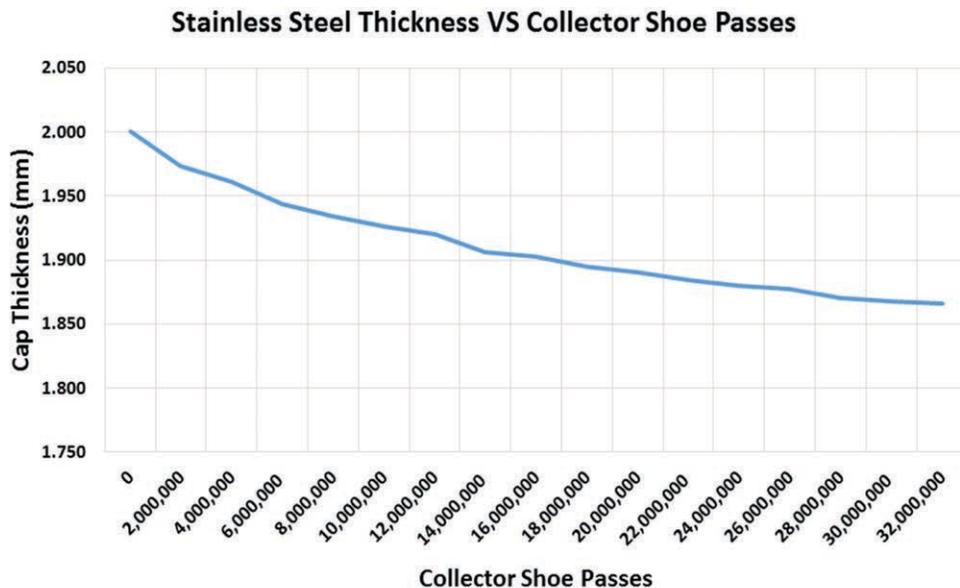

Example 4500 Amp Components

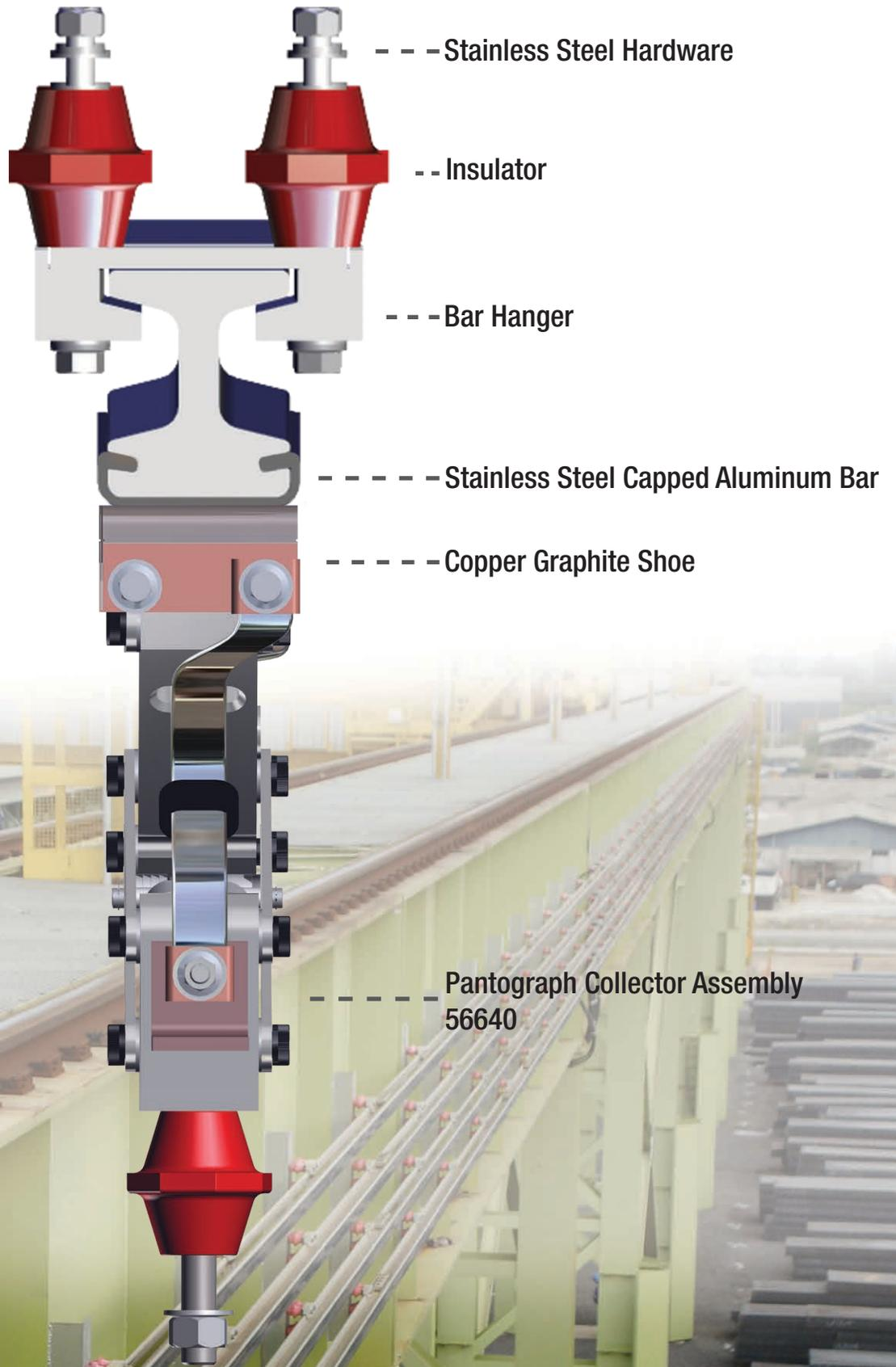

Hevi-Bar MD™ Conductor Bar Information

2200 Amp Conductor Bar System

2200 Amp Conductor Bar System Components			
Item	Length ft (m)	2mm Crimped SS Cap	
		Part No.	Wgt lb (kg)
Conductor, 9M	29.53 (9)	563106	154 (69.9)
Conductor, 12M	39.37 (12)	563106B	205 (93.0)
Expansion	19.69 (6)	561397	117 (53.1)
Splice	1.31 (0.4)	563115	5.0 (2.3)
Hanger	n/a	538648	3.0 (1.4)
Power Feed 4 Lug	0.66 (0.2)	562954	2.8 (1.3)
Power Feed 8 Lug	1.31 (0.4)	563118	5.0 (2.3)
Power Interrupting Section	19.69 (6)	561401	111 (50.3)
Anchor	n/a	563121	1.5 (0.7)

2200 Amp Conductor Bar Specifications		
Resistance	$\Omega/1000$ ft	0.004300
	$10^{-6} \Omega/m$	14.10
Mass	lb/ft	5.22
	kg/m	8.20
Max Hanger Spacing	ft (m)	9.84 (3)

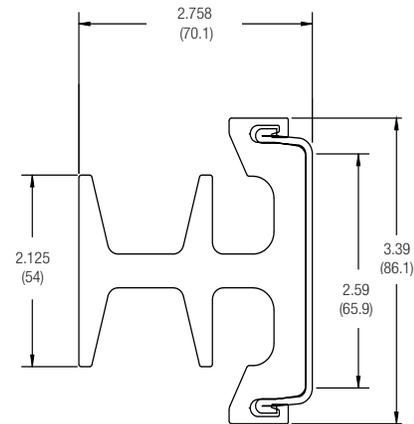
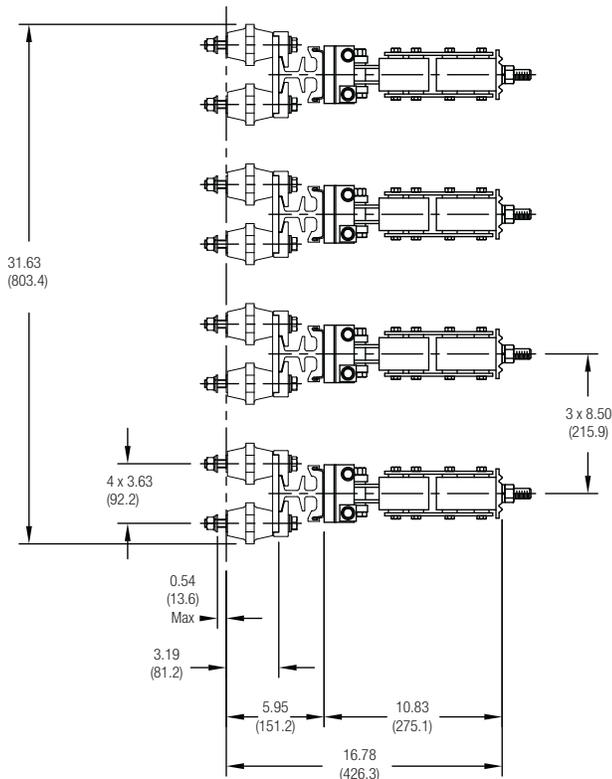

Bar Profile - Crimped Cap

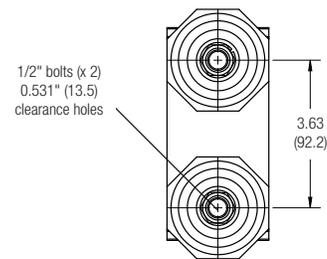

Hanger Mounting bolt Pattern

Laterally Mounted System Dimensions. Can be rotated 90° clockwise for under-running system

3800 Amp Conductor Bar System

3800 Amp Conductor Bar System Components					
		2mm Crimped SS Cap		4mm Welded SS Cap	
Item	Length ft (m)	Part No.	Wgt lb (kg)	Part No.	Wgt lb (kg)
Conductor, 9m	29.53 (9)	542431B	225 (102)	542405B	285 (129)
Conductor, 12m	39.37 (12)	542431	300 (136)	542405	380 (172)
Expansion	19.69 (6)	561398	285 (129)	561398	285 (129)
Splice	1.31 (0.4)	563189	6.8 (3.1)	563189	8.6 (3.9)
Hanger	n/a	531606	7.8 (3.5)	531606	7.8 (3.5)
Power Feed 4 lug	0.66 (0.2)	562922	6.1 (2.8)	562922	6.1 (2.8)
Power Feed 8 lug	1.31 (0.4)	563162	12.2 (5.5)	563162	12.2 (5.5)
Power Interrupting Section	19.69 (6)	563229	230 (104)	563229	230 (104)
Anchor	n/a	531858	2.5 (1.1)	531858	2.5 (1.1)



3800 Amp Conductor Bar Specifications			
		2 mm	4mm
Resistance	$\Omega/1000$ ft	0.002648	0.002697
	$10^{-6} \Omega/m$	8.69	8.85
Mass	lb/ft	7.61	9.53
	kg/m	11.35	14.30
Max Hanger Spacing		ft (m)	9.84 (3)

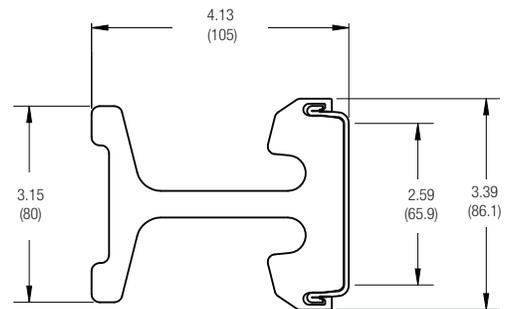

Bar Profile - Crimped Cap

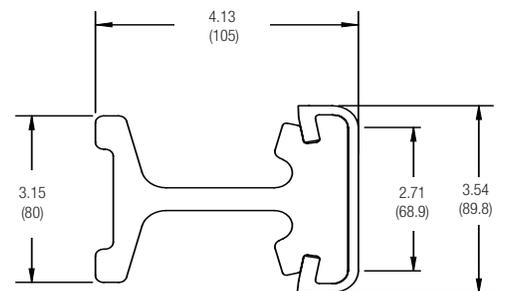

Bar Profile - Welded Cap

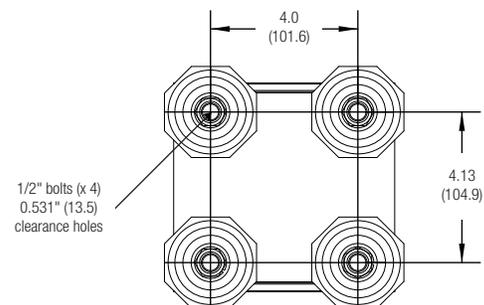

Hanger Mounting Bolt Pattern

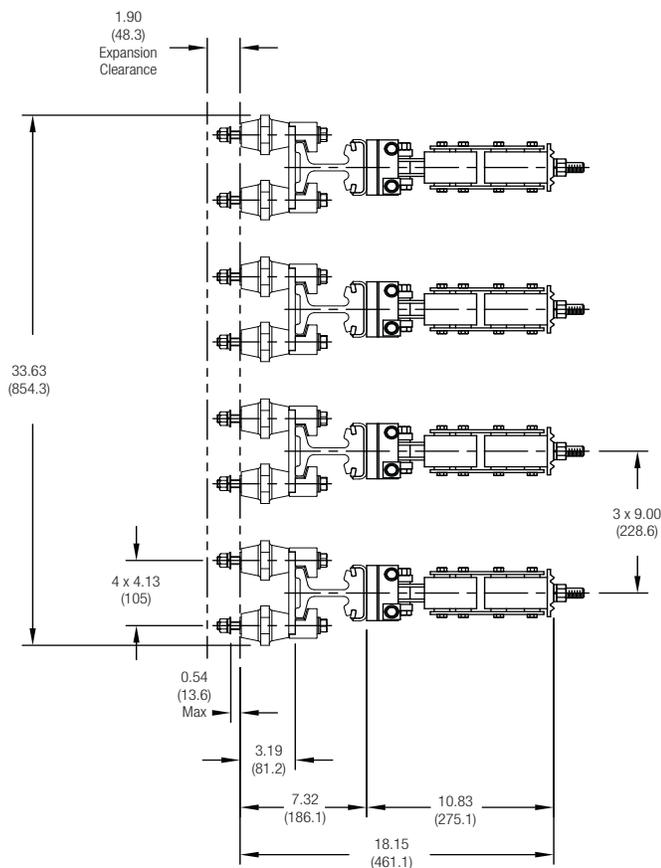

Laterally Mounted System Dimensions. Can be rotated 90° clockwise for under-running system

Hevi-Bar MD™ Conductor Bar Information

4500 Amp Conductor Bar System

4500 Amp Conductor Bar System Components					
		2mm Crimped SS Cap		4mm Welded SS Cap	
Component	Length ft (m)	Part No.	Wgt lb (kg)	Part No.	Wgt lb (kg)
Conductor, 9m	29.53 (9)	36529B	292 (132)	50744B	338 (153)
Conductor, 12m	39.37 (12)	36529C	389 (176)	50744	450 (204)
Expansion	19.69 (6)	561398	285 (129)	561398	285 (129)
Splice	1.31 (0.66)	563189	8.6 (3.9)	563189	8.6 (3.9)
Hanger	n/a	531606	7.8 (3.5)	531606	7.8 (3.5)
Power Feed 4 lug	0.66 (0.2)	562922	6.1 (2.8)	562922	6.1 (2.8)
Power Feed 8 lug	1.31 (0.4)	563162	12.2 (5.5)	563162	12.2 (5.5)
Power Interrupting Section	19.69 (6)	563229	230 (104)	563229	230 (104)
Anchor	n/a	531858	2.5 (2.1)	531858	2.5 (2.1)



4500 Amp Conductor Bar Specifications			
		2 mm Cap	4mm Cap
Resistance	$\Omega/1000$ ft	0.002000	0.002130
	$10^{-6} \Omega/m$	6.56	6.99
Mass	lb/ft	9.88	11.43
	kg/m	14.70	17.15
Max Hanger Spacing	ft (m)	9.84 (3)	9.84 (3)

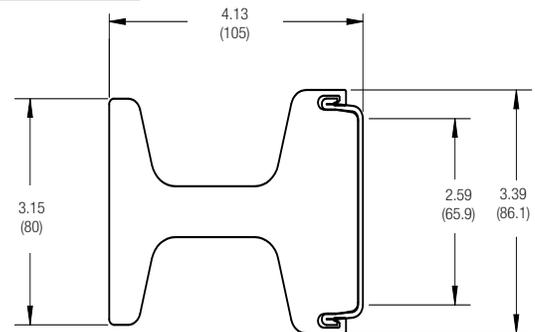

Bar Profile - Crimped Cap

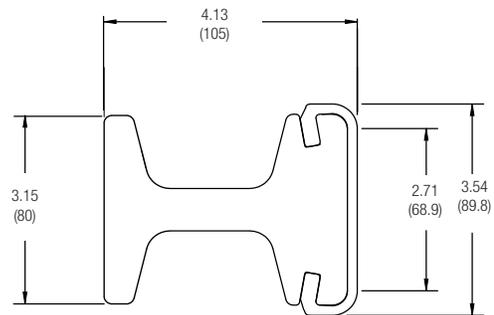

Bar Profile - Welded Cap

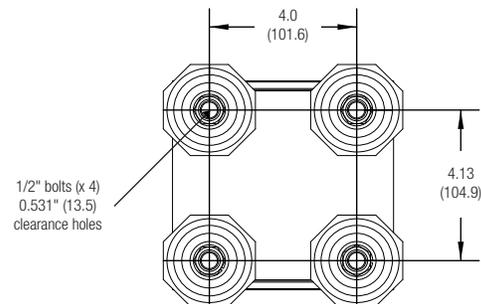
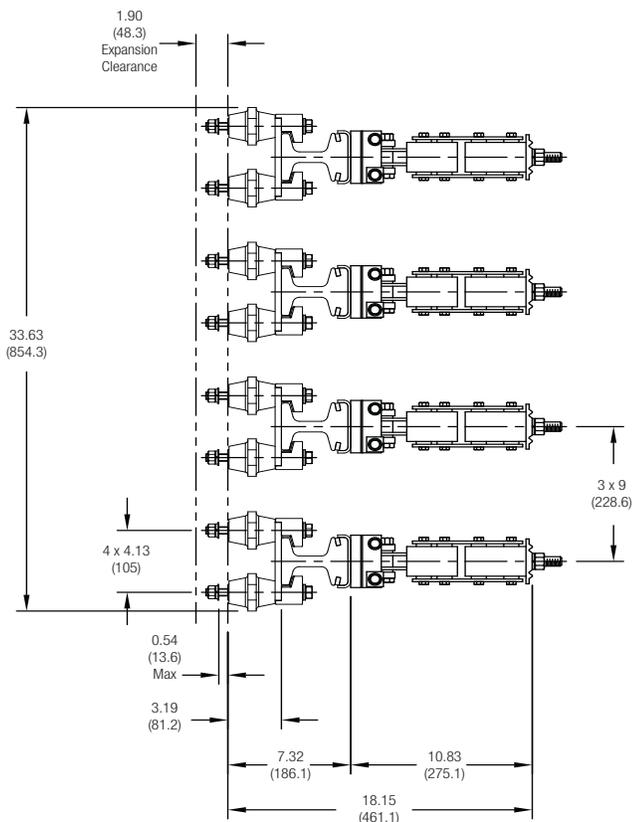

Hanger Mounting Bolt Pattern

Laterally Mounted System Dimensions. Can rotated 90° clockwise for under-running system

6000 Amp Conductor Bar System

6000 Amp Conductor Bar System Components			
Item	Length ft (m)	6 mm Welded SS Cap	
		Part No.	Wgt lb (kg)
Conductor, 9m	29.53 (9)	558094C	504 (229)
Conductor, 12m	39.37 (12)	558094B	672 (305)
Expansion	19.69 (6)	561400	418 (190)
Splice	1.33 (0.41)	563225	13 (95.9)
Hanger	n/a	562195	7.8 (3.5)
Power Feed 4 lug	0.66 (0.2)	562920	6.3 (2.9)
Power Feed 8 lug	1.31 (0.66)	561404	12.5 (5.7)
Power Interrupting Section	19.69 (6)	561405	352 (160)
Anchor	n/a	562120	2.0 (0.9)



6000 Amp Conductor Bar Specifications		
Resistance	$\Omega/1000$ ft	0.001400
	$10^{-6} \Omega/m$	4.59
Mass	lb/ft	17.10
	kg/m	26.20
Max Hanger Spacing	ft (m)	9.84 (3)

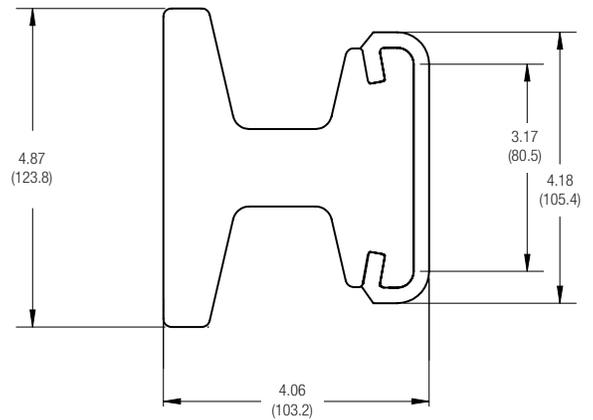
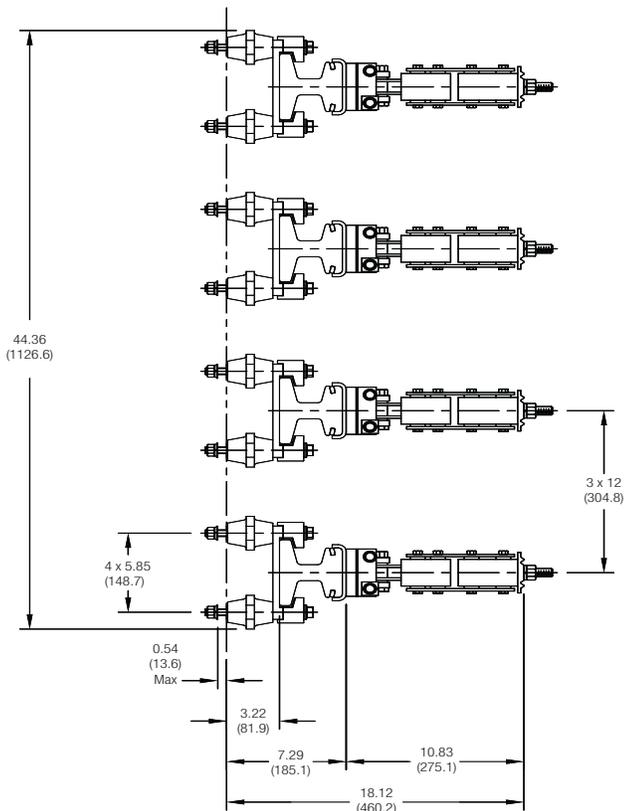

Bar Profile - Welded Cap

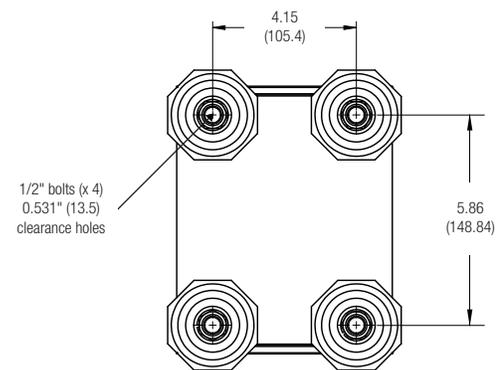

Hanger Mounting Bolt Pattern

Laterally Mounted System Dimensions. Can be rotated 90% clockwise for under-running system

Hevi-Bar MD™ Power Feeds

Power Feeds come with pre-drilled 1/2" clearance holes (0.531") and 1/2" bolts, nuts, and washers. Installers will need to drill 1/2 clearance holes (0.531") in the conductor web to attach the Power Feed to the conductor bar.

Lug spacing is 3.93" (100 mm). 1 to 4 lug versions are 7.87" (200 mm) long. 5 to 8 lug versions are 15.75" (400 mm) long.

Note: Cable lugs shown are for illustration only. Due to the wide variety of sizes, these are customer supplied. Contact Conductix-Wampfler for compression lugs to fit your cable.

For 2200 Amp Crimped Cap Bar

562954 For 1 to 4 lugs

563118 For 5 to 8 lugs

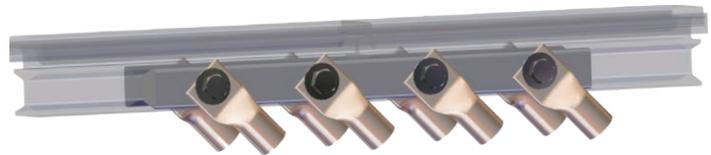

For 3800 Amp Crimped Cap or Welded Cap Bar

562922 For 1 to 4 lugs

563162 For 5 to 8 lugs



For 4500 Amp Crimped Cap or Welded Cap Bar

562922 For 1 to 4 lugs

563162 For 5 to 8 lugs



For 6000 Amp Welded Cap Bar

562920 For 1 to 4 lugs

561404 For 5 to 8 lugs



Hevi-Bar MD™ Pantograph Collector

Part No. 566440

Wgt lb (kg): 24 (10.9)

- 1000 amp / 600 volt rated
- Self-lubricating tandem copper graphite shoes eliminate loss of contact.
- Reliable bolted clamp system holds the shoe in the holder; easy to replace the shoe if needed.
- Arm linkage articulates vertically within a 5.9" (150 mm) range.
- Horizontally rigid to accurately track the bar.

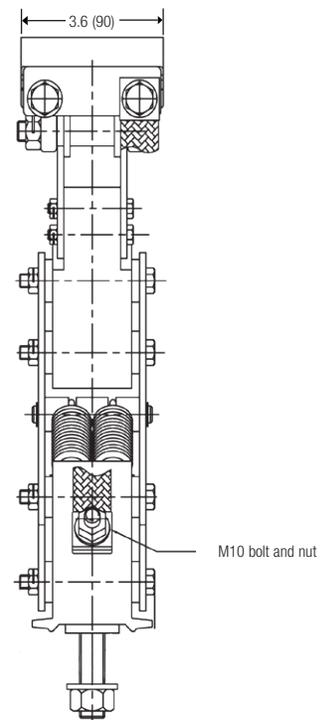
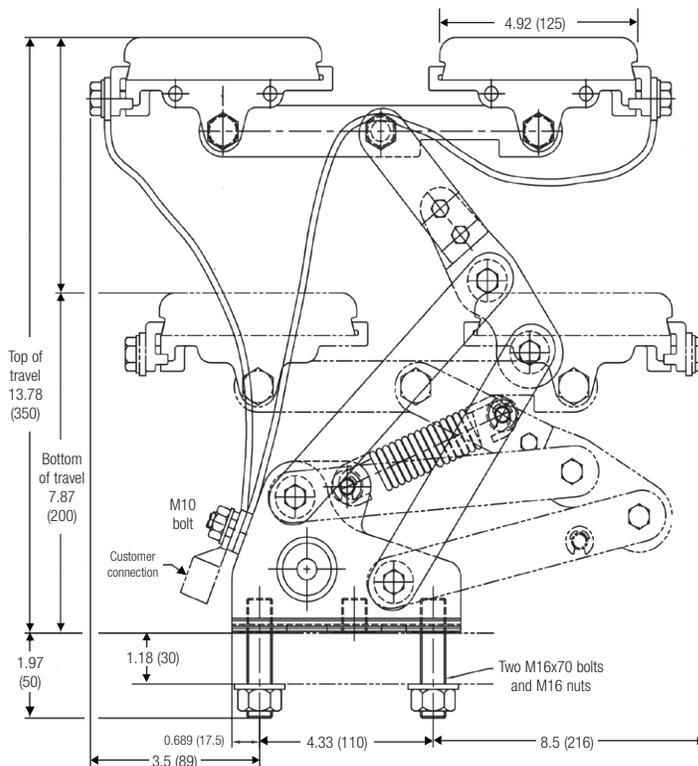
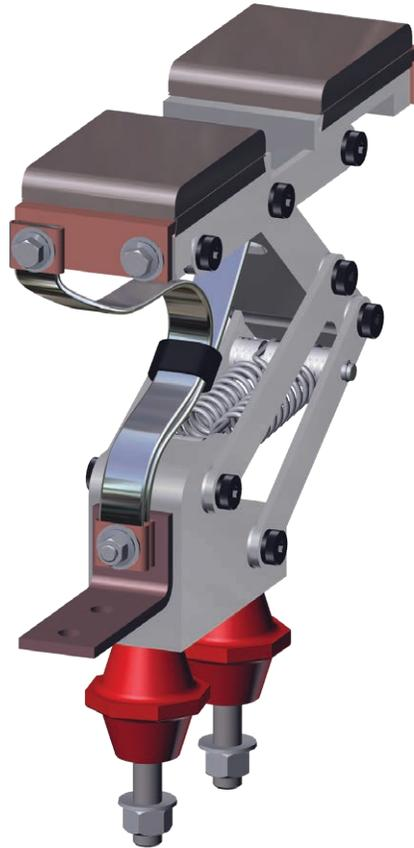

Hevi-Bar MD

The Service Advantage



Our Service Team Comes to You

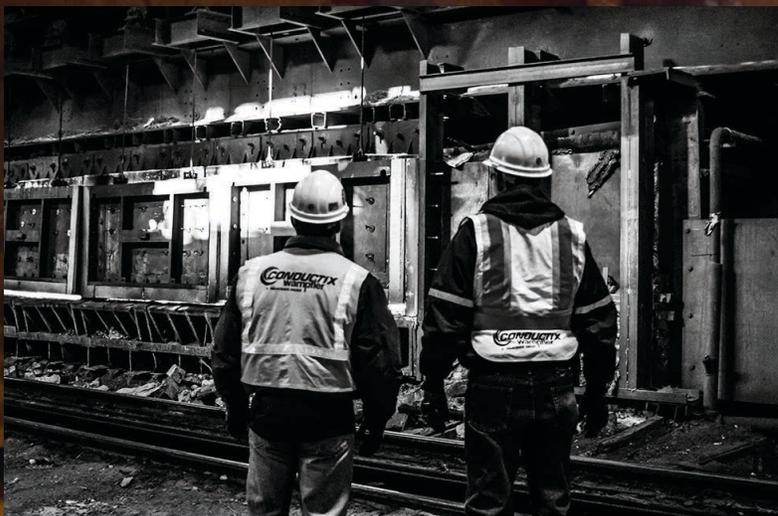

Engineering and Technical Services

As a system supplier, Conductix-Wampfler offers complete solutions, including qualified consulting, system engineering, and technical services. We help you select the optimal components, deliver the necessary parts and services to complete your project, and employ the correct logistic concept, to include on-site commissioning.

We custom-engineer systems to meet our customers' requirements and have extensive experience in the demanding iron/steel mill environment.

The Service Advantage

We offer the full range of power delivery systems for moving machinery. Products include cable festoon systems, conductor bar, cable reeling equipment, cable chain systems, radio remote controls, and wired push-button controls. We offer on-site installation assistance and installation supervision by request.

A Few of the many global Iron/Steel companies we are proud to serve:

United States

- AK Steel
- ArcelorMittal
- Gerdau Ameristeel
- Gerdau Macsteel
- Nucor
- Scott Forge
- Severstal
- Steel Dynamics
- Thyssenkrup
- United States Steel Corporation
- AM/NS
- Outokumpu Stainless

Mexico / Latin America

- ACINDAR Argentina
- Aco Minas Gerais Brazil
- AHMSA Mexico
- Albonorte Foundries Chile
- ALUAR Argentina
- APM Mexico
- Bauxilum Venezuela
- Chagres Foundries Chile
- Cia. Sid. Huachipato Chile
- CSN Brazil
- HYLSA Mexico
- IMPSA Mexico
- ISPAT Mexico
- Sider Peru
- SIDERAR Argentina
- SIDOR Venezuela

www.conductix.us

USA / LATIN AMERICA

10102 F Street
Omaha, NE 68127

Customer Support

Phone +1-800-521-4888

Fax +1-800-780-8329

Phone +1-402-339-9300

Fax +1-402-339-9627

info.us@conductix.com

latinamerica@conductix.com

CANADA

18450 J.A. Bombardier
Mirabel, QC J7J 0H5

Customer Support

Phone +1-800-667-2487

Phone +1-450-565-9900

Fax +1-450-851-8591

info.ca@conductix.com

MÉXICO

Calle Treviño 983-C
Zona Centro
Apodaca, NL México 66600

Customer Support

Phone (+52 81) 1090 9519

(+52 81) 1090 9025

(+52 81) 1090 9013

Fax (+52 81) 1090 9014

info.mx@conductix.com

BRAZIL

Rua Luiz Pionti, 110
Vila Progresso
Itu, São Paulo, Brasil
CEP: 13313-534

Customer Support

Phone (+55 11) 4813 7330

Fax (+55 11) 4813 7357

info.br@conductix.com

Contact us for our Global Sales Offices

